

The future is straightforward and safe:
Gear units and motors in a modular system

Gearmotors



Another milestone at SEW-EURODRIVE: Safe worldwide standards for each drive solution

This brochure on our extremely versatile modular for gearmotors documents once more the values we live by in our company. It shows that you can rely on SEW-EURODRIVE in every respect because the modular system fulfills our brand promise in many ways. It includes technically unique innovations, opens up even more possibilities for selecting the right drive solution, simplifies the configuration of components and provides investment security worldwide.

The redevelopment of the tried and tested DT/DV motor series has turned all gearmotor variants of SEW-EURODRIVE into future-proof innovation carriers of the highest quality. The new AC motor modular system with the DR.. series encompasses the entire range of efficiency ratings, including energy-efficient motors. This is a logical consequence of the developments in environmental policies worldwide.

In the future, gearmotors from SEW-EURODRIVE will continue to fulfill all standards worldwide. What's more, by integrating them into a standardized modular system, SEW-EURODRIVE has become the first manufacturer to offer energy-efficient motors along with conventional AC motors within one series, including three brake variants for each motor. This ensures a much better price for the energy-efficient motor. Last but not least, the DR.. motor is the best SEW-EURODRIVE motor that has ever been launched.

Driving the world – with innovative drive solutions for all industries and for every application. Products and systems from SEW-EURODRIVE are used all over the world. Be it in the automotive, building materials, food and beverage or metal-processing industry – the decision to use drive technology “made by SEW-EURODRIVE” stands for reliability for both functionality and investment.





At the same time, the new motor series offers the same advantages that have made the DT/DV series successful in millions of drive solutions worldwide. These include, above all, performance, compact design, versatility, reliability and long service life. Together with many other benefits, also in combination with our drive electronics components, they have turned our gearmotors into what they are today:

State-of-the-art drive technology.

This brochure gives you a complete overview of all possible gearmotor variants. The content is divided into gear units, motors and accessories/options. At the end, clearly structured tables give an overview of matching components for your individual drive solution.



The area of application for our gear units: the world

We do not exaggerate when we proudly say: There is no industry and no drive application in the world for which our gear units in combination with the required motors would not offer excellent performance. Areas of application include automotive engineering, the food and beverage industry, logistics (airport logistics, intralogistics and port logistics), the wood processing, construction and construction materials industries, and countless special applications, for example in theaters.

Depending on power requirements, space and technical specifications, SEW-EURODRIVE offers the full range of gear units in a modular system:

Helical, parallel-shaft helical, helical-bevel, helical-worm, and SPIROPLAN® right-angle gear units. Input covers, motor adapters and various clamping joints in line with the gear unit family are also available from SEW-EURODRIVE.



Helical gear units (R): always the optimum space/performance ratio

Six single-stage and fourteen two- and three-stage sizes covering a power range from 50 to 18,000 Nm: Our helical gear units always offer an optimum ratio between performance and space requirements. The fine graduation and variety of torque ratings and gear ratios is

peerless. They also satisfy demands for high output speeds or low weight due to the many available sizes.

The result: A helical gear unit is always suitable.

Helical gear units (R)

Type	Maximum output torque [Nm]	Gear unit reduction ratio [i]	Gear unit reduction ratio Multi-stage gear unit [i]
RX series (single-stage) Sizes 57 / 67 / 77 / 87 / 97 / 107	69 ... 830	1.30 ... 8.65	–
R series (two- and three-stages) Sizes 07 / 17 / 27 / 37 / 47 / 57 / 67 / 77 / 87 / 97 / 107 / 137 / 147 / 167	50 ... 18,000 (also with reduced backlash)	3.21 ... 289.74	90 ... 27,001
RM series (two- and three-stages) Sizes 57 / 67 / 77 / 87 / 97 / 107 / 137 / 147 / 167	450 ... 18,000	4.29 ... 289.74	134 ... 27,001



The gear units of the R series are available in the following designs:

- Single- or multi-stage
- Foot- or flange-mounted
- Foot- and flange-mounted
- Flange-mounted with extended output bearing hub

Parallel-shaft helical gear units (F): tailor-made for adverse space conditions

The particularly slim-fit parallel-shaft helical gear units are used wherever space is limited. Various mounting positions and designs make for a large range of applications even under adverse conditions. Thanks to its design

characteristics and its large torque range from 120 to 18,000 Nm, this standard gear unit is the ideal solution for many materials handling and process engineering applications.

Parallel-shaft helical gear units (F)

Type	Maximum output torque [Nm]	Gear unit reduction ratio [i]	Gear unit reduction ratio Multi-stage gear unit [i]
F series (two- and three-stages) Sizes 27 / 37 / 47 / 57 / 67 / 77 / 87 / 97 / 107 / 127 / 157	120 ... 18,000 (also with reduced backlash)	3.77 ... 281.71	87 ... 31,434



Helical-bevel gear units (K): strong performance and high efficiency in a very compact design

The compact design of all our gear units is most obvious in our helical-bevel gear units. They are sophisticated right-angle gear units for all engineering applications that require space-saving installation. At the same time, they offer a powerful torque range from 200 to 50,000 Nm.

They ensure a remarkably high degree of efficiency of more than 96 per cent in both directions of rotation and for any input speed. A gear unit built to last: The gearing is designed for high endurance and makes for a high-torque, wear-free drive.

Helical-bevel gear units (K)

Type	Maximum output torque [Nm]	Gear unit reduction ratio [i]	Gear unit reduction ratio Multi-stage gear unit [i]
K series Sizes 37 / 47 / 57 / 67 / 77 / 87 / 97 / 107 / 127 / 157 / 167 / 187	200 ... 50,000 (also with reduced backlash)	3.98 ... 197.37	94 ... 32,625



The gear unit series F and K are available in the following designs:

- Foot- or flange-mounted
- In B5 flange-mounted design
- In B14 flange-mounted design
- With solid shaft or hollow shaft
- With hollow shaft with keyed connection, shrink disk, splined hollow shaft or TorqLOC®

Helical-worm gear units (S): cost effectiveness due to simple design

The strength of helical-worm gear units is their simple mechanical structure. Tailored individually to torque and speed requirements, they save installation space and costs when implemented in simple applications. In addition to the large gear ratio in the worm gear stage, our helical-worm gear units also offer a significantly higher level

of efficiency than mere worm gear units. Power is transmitted linearly to the drive shaft and the torque shocks are reduced – making for a low noise level. Their torque range runs from 92 to 4,000 Nm.

Helical-worm gear units (S)

Type	Maximum output torque [Nm]	Gear unit reduction ratio [i]	Gear unit reduction ratio Multi-stage gear unit [i]
S series Sizes 37 / 47 / 57 / 67 / 77 / 87 / 97	92 ... 4,000	6.80 ... 288.00	110 ... 33,818



SPIROPLAN® right-angle gear units (W): low-noise lightweights

The SPIROPLAN® right-angle gearmotors do their job reliably and quietly: In the power range from 0.09 to 4.0 kW, the SPIROPLAN® series provides output torques up to 180 Nm – its wear-free gearing ensuring very quiet operation. In combination with the compact design and the lightweight aluminum housing, the noise level is almost perfectly low.

The oil fill is independent of the mounting position, which means SPIROPLAN® gearmotors can be used universally while requiring almost no maintenance. The gear ratio range offers very high output speeds and optimized mechanical efficiency.

SPIROPLAN® right-angle gear units (W)

Type	Maximum output torque [Nm]	Gear unit reduction ratio [i]	
W10	25	3.91 ... 75.00	
W20	40	6.57 ... 75.00	
W30	70	6.57 ... 75.00	
W37	110	3.20 ... 69.05	
W47	180	3.27 ... 74.98	



The gear units of the S and W series are available in the following designs:

- Foot- or flange-mounted
- In B5 flange-mounted design
- In B14 flange-mounted design
- With solid shaft or hollow shaft

Additional variants of the S gear unit series:

- With hollow shaft with keyed connection, shrink disk, splined hollow shaft or TorqLOC®

The new modular motor system: One single series for millions of drive combinations

Configuring gearmotors with AC motors from SEW-EURODRIVE has never been easier: A modular system comprising the motors of the new DR.. series offers all efficiency levels, including energy-efficient motors. In the development of energy-efficient motors, SEW-EURODRIVE became the first company in the world to succeed in using die-cast copper technology in industrial high-volume series production in 2002.

As another new development in the new modular system, SEW-EURODRIVE offers a selection of three different brake sizes for each motor size as well as cost-optimized encoders integrated into the motor.

All motor options and variants of the new DR.. series are available for all efficiency classes. They comply with all worldwide standards and already fulfill the forthcoming IEC standard. They bring a whole range of unique benefits to planners and users.

Overview of benefits:

- Easiest configuration and ordering
- Configuration of all motor variants from just one series
- Even more options, even fewer restrictions
- Compact design saves space and costs
- Future-proof, also as regards environmental protection (standards)
- Reduced prices for energy-efficient motors due to integration
- Reduced prices due to selection of different brake sizes



The efficiency classes of the future

The efficiencies of the energy-efficient motors from SEW-EURODRIVE comply with international limit values and standards, often they surpass them. The motors are also available as 2- and 6-pole variants in IE3, IE2 and IE1.

The list of standards includes:

- **Europe** ErP 2009/125/EC
- **Australia/New Zealand** MEPS 2006
- **USA** EISA 2007
- **Canada** CSA C390
- **Brazil** NBR 17094, PROCEL
- **Korea** REELS
- **China** CEL 2011
- and other (Chile, Turkey,...)

Premium Efficiency	IE3
	<p>Europe, Australia, New Zealand, USA and Canada</p> <ul style="list-style-type: none"> – Extremely high levels of efficiency – DRP.. type AC motors (energy-efficient motors): Motor size 90 and larger: 0.75 ... 160 kW – Copper or aluminum die-cast rotor cage
High Efficiency	IE2
	<p>Europe, Australia, New Zealand, USA, Canada, Brazil, Korea, China ...</p> <ul style="list-style-type: none"> – High levels of efficiency – DRE.. type AC motors (energy-efficient motors): Motor size 80 and larger: 0.75 ... 200 kW – Copper or aluminum die-cast rotor cage
Standard Efficiency	IE1
	<p>Asia, Africa, Central and South America (without Brazil)</p> <ul style="list-style-type: none"> – Improved levels of efficiency – DRS.. type AC motors (standard motor): Motor size 71 and larger: 0.37 ... 200 kW – Copper or aluminum die-cast rotor cage

The technical data (4-pole motors) is listed on page 20.

The brake variants in the modular system

Smaller holding torques are required for inverter operation, and less braking work for energy-efficient motors. Today's brakes are often dimensioned too large for this purpose. This is why the new modular motor system from SEW-EURODRIVE makes it possible to choose from up to three brake sizes for each motor size (overview on page 21).

Additional features of the brakes:

- Manual brake release
 - automatic disengaging function
 - lockable
- Function and wear monitoring



The built-in encoder is fully integrated into the motor

Many applications require only speed and position detection. Previously, elaborate and cost-intensive external encoders were mounted to the motor or initiators were used for complex sensing to fulfill these requirements.

SEW-EURODRIVE offers a unique and cost-optimized solution: the built-in encoder. The encoder is fully integrated into the motor and connected in or at the motor terminal box. Due to its low degree of complexity, the built-in encoder can be retrofitted.



Installation flexibility also on the input end

SEW-EURODRIVE offers optimum solutions for the input end in line with the gear unit family, to provide more flexibility and efficiency also on the motor side. Input covers and motor adapters are characterized by compact dimensions, low weight and long service life. Optimum integration with our gear units improves overall efficiency of the drive system.

SEW-EURODRIVE offers eight different cover sizes for different power ratings. The options enable optimum connection of the drive components depending on the gear unit and the drive task. Take the height adjustment for covers, for example, with a height-adjustable motor moun-

ting platform that allows for simple installation and startup. Or the integrated backstop, which ensures compact drive design and optimum operating characteristics.



The input covers and adapter variants are excellent examples to show how our gear units can provide more efficiency for any drive anywhere.

The adapters also increase the number of possibilities

In addition to the integrated torque limiting coupling, there is an adapter variant with integrated hydraulic centrifugal coupling. It is equipped with protection against overheating as standard. An integrated mechanical brake and an integrated backstop are optional. With the

AM motor adapters, all IEC motors size 63 to 280 and all NEMA motors size 56 to 365 can be mounted to the 7-series gear units. The AQ adapter accepts servomotors – either with positive key connection (AQA) or with non-positive connection as clamping ring hub (AQH).



Installation does not get much easier: with the TorqLOC® hollow shaft mounting system

Simple

The new design of the TorqLOC® hollow shaft mounting system makes for simple assembly and significantly improves removal of the drive even after lengthy periods of operation. SEW-EURODRIVE will deliver the drive with the bushing for the respective diameter. The operator will install the clamping ring on the customer shaft and the drive can be simply mounted and fixed. The installation is simple and fast because there are no interference fits that have to be overcome. Removal will be just as simple and takes place in reverse order.

Economical

The TorqLOC® hollow shaft mounting system makes it possible to use drawn, unprocessed material up to quality level h11 for customer shafts, reducing costs even further. No additional machining of the customer shaft is required.

Flexible

Planned down to the last detail: Up to four different rated diameters can be adapted with one gear unit size, resulting in a reduction of variants.

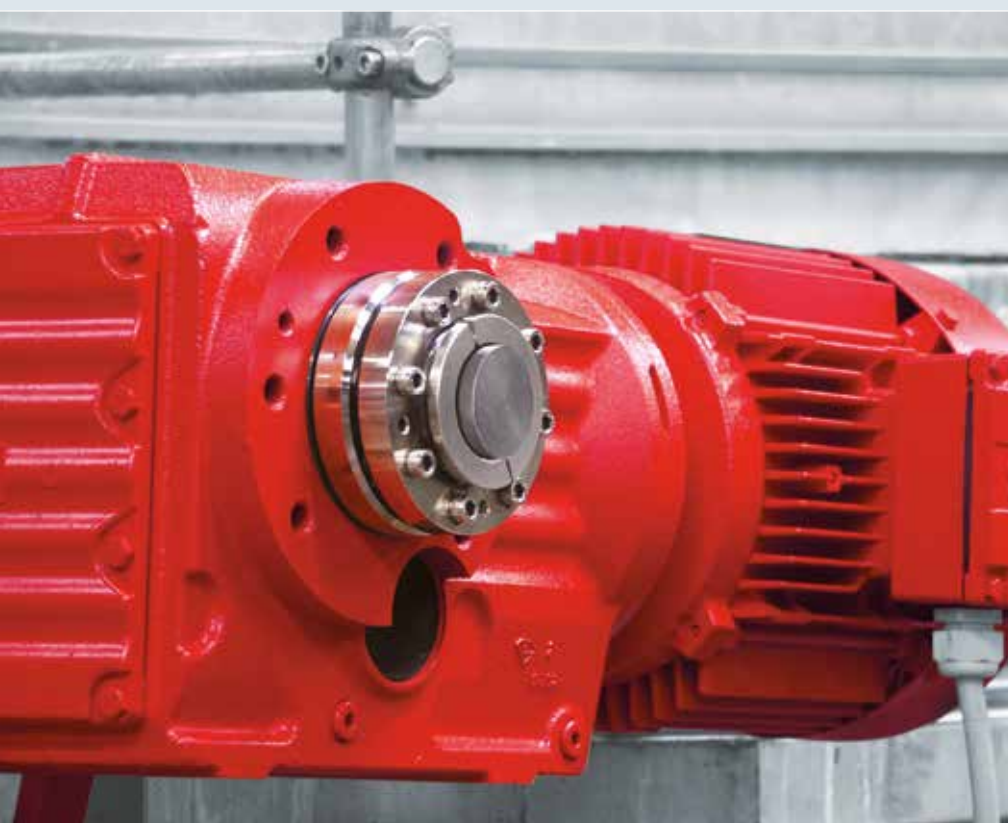

Awards

The trade journal "Plant Engineering" awarded the "Product of the Year 2002". The award is given to innovative products which lead to ground-breaking improvements at the production level.

SEW-EURODRIVE received the "Silver Award" for TorqLOC® in the category "Power Transmission". The "Silver Award" was handed out at the National Plant Engineering Show in Chicago in early March 2003.

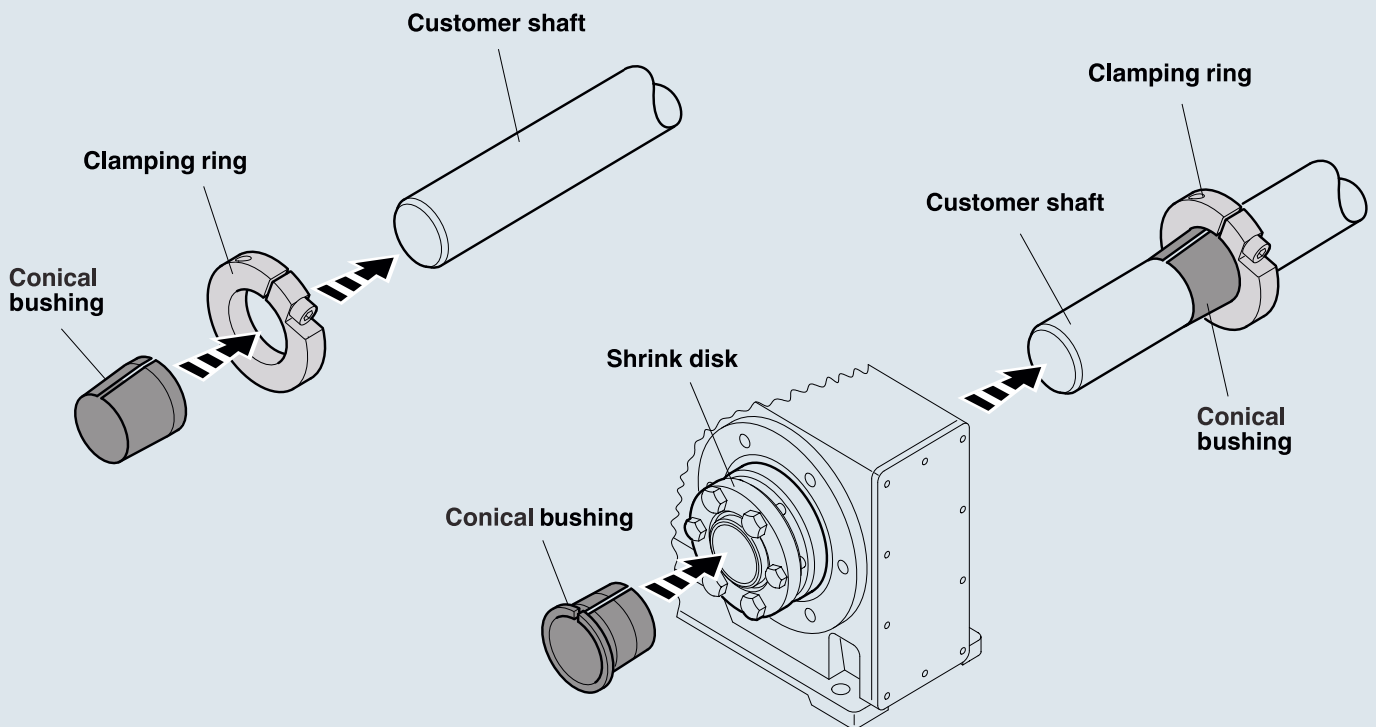

All you need is a PC to discover our range of almost unlimited possibilities

Printed documentation, CD-ROMs or downloads: As diverse as the product range of SEW-EURODRIVE are the tools supporting the designer in the planning and design phase. The comprehensive information material and the product-supporting software are fast and simple tools for selecting a drive and integrating it into the machine or system design.

Order or download from the Internet

The series of publications entitled "Drive Engineering – Practical Implementation," such as volume 1 "Project Planning for Drives,"

documentation for different products (Docu ROMs) and presentations (CBI-ROM) on CD-ROM, or operating instructions, manuals and catalogs offer detailed basic information.



Workbench

The new SEW Workbench is a planning and configuration tool to specify SEW-EURODRIVE products. The user can employ simple graphical elements to configure even complex systems and check their functionality quickly and easily. A variety of new functions offers our customers the opportunity to find a drive solution to meet their individual requirements and discuss the results with an SEW-EURODRIVE sales representative.

The SEW Workbench offers catalog selection functions for gearmotors, electronic components and prefabricated cables as well as accessories and options.

Calculation of the CAD data ensures the creation of true-to-scale drawings of SEW-EURODRIVE products in the 2D formats DXF and DWG as well as in the 3D formats SAT, STEP, IGES, VRML,

VDAFS and 3D-DXF. Thanks to the high degree of functionality, spare parts lists, mounting position sheets, dimension sheets and operating instructions are determined automatically.

To use SEW Workbench, all you need to do is register via the SEW-EURODRIVE customer portal DriveGate® once you have received the data DVD (<https://portal.drivagate.biz>). An Internet update service keeps the products and functions up-to-date.

The SEW Workbench is available in the following languages:

German, English, French, Dutch, Spanish, Portuguese, Russian, Czech, and Polish.

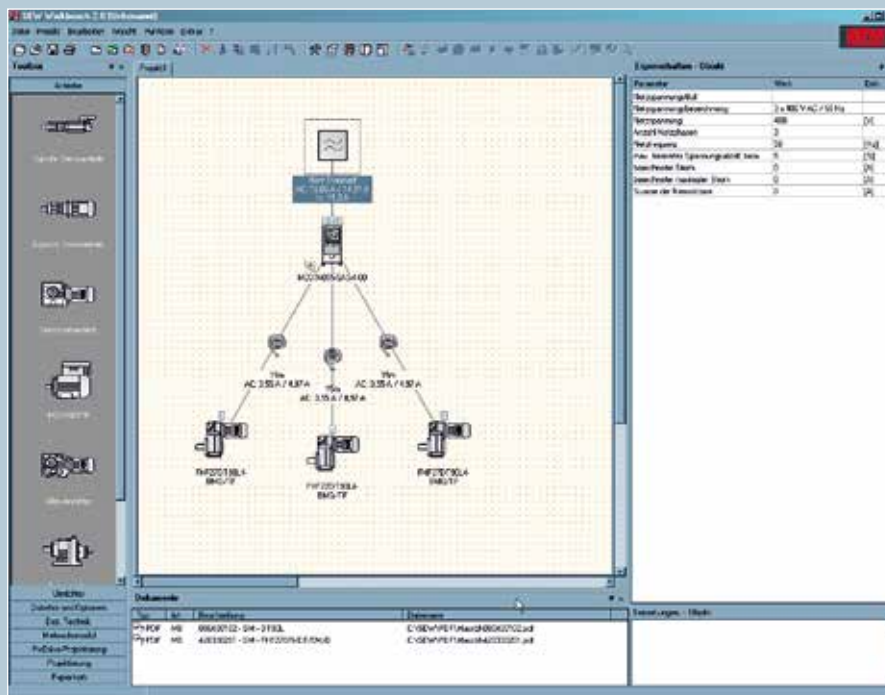

Technical data (4-pole motors)

Motors of the DR.. series / 50 Hz motor power [kW]

Motor size	Standard motors	Energy-efficient motors	
	Standard Efficiency DRS.. type	High Efficiency DRE.. type	Premium Efficiency DRP.. type
DR71	0.37 ... 0.55	–	–
DR80	0.75 ... 1.1	0.37 ... 0.75	–
DR90	1.5 ... 2.2	1.1 ... 1.5	0.75 ... 1.1
DR100	3.0 ... 4.0	2.2 ... 3.0	1.5 ... 2.2
DR112	4.0	3.0	–
DR132	5.5 ... 9.2	4.0 ... 7.5	3.0 ... 5.5
DR160	9.2 ... 15	7.5 ... 11	5.5 ... 7.5
DR180	15 ... 30	11 ... 22	7.5 ... 18.5
DR200	30	30	22
DR225	37 ... 55	37 ... 45	30 ... 37
...
DR315	110 ... 200	110 ... 200	90 ... 160

Motors of the DR.. series / 60 Hz motor power [kW]

Motor size	Standard motors	Energy-efficient motors	
	Standard Efficiency DRS.. type	High Efficiency DRE.. type	Premium Efficiency DRP.. type
DR71	0.37 ... 0.55	–	–
DR80	0.75 ... 1.1	0.37 ... 0.75	–
DR90	1.5 ... 2.2	1.1 ... 1.5	0.75 ... 1.5
DR100	3.0 ... 4.0	2.2 ... 3.7	–
DR112	4.0	3.7	2.2
DR132	5.5 ... 9.2	4.0 ... 7.5	3.7
DR160	9.2 ... 15	7.5 ... 11	5.5 ... 11
DR180	15 ... 30	11 ... 22	11 ... 22
DR200	30	30	22
DR225	37 ... 55	37 ... 45	22 ... 37
...
DR315	110 ... 225	110 ... 225	90 ... 160

Overview of brake combinations for DR.. motors

Motor size	Maximum braking torque [Nm]									
	5	10	20	55	110	200	300	600	1200	2400
DR71	BE05	BE1	BE2	BE5	BE11	BE20	BE30	BE32
DR80										
DR90										
DR100										
DR112										
DR132										
DR160										
DR180										
DR200										
DR225										
...										
DR315									BE120	BE122

Overview of encoder combinations for DR.. motors

Motor size	Built-in encoder	Add-on encoder					Other
	Signal format	Signal format			Multi-turn signal format		
	HTL	Sin/Cos	TTL	HTL	Sin/Cos RS485	Sin/Cos M-SSI	
DR71	EI7C	ES7S	ES7R	ES7C	AS7W	AS7Y	On request
DR80							
DR90							
DR100							
DR112							
DR132							
DR160	-	EG7S	EG7R	EG7C	AG7W	AG7Y	
DR180							
DR200							
DR225							
...		
DR315	-	EH7Y	On request	On request	On request	AH7Y (TTL+M-SSI)	

Selection of additional features
for the modular AC motor system



Additional feature	Characteristic	SEW type designation
Brakes		BE with size designation
Manual brake release	Automatic disengaging function (BE05-32)	HR
	Lockable (BE05-122)	HF
Brake monitoring	Wear/function	DUB
Built-in encoder (DR71 ... 132)	HTL	EI7C / EI76 / EI72 / EI71
Shaft-centered add-on encoder (DR71 ... 132 / DR160 ... 225)	Sin/Cos	ES7S / EG7S
	HTL	ES7C / EG7C
	TTL	ES7R / EG7R
	SSI	AS7Y / AG7Y
	RS-485 Multi-turn	AS7W / AG7W
Shaft-centered hollow shaft encoder (DR315)	Sin/Cos	EH7S
	SSI Multi-turn	AH7Y
Thermal motor protection	3 PTC resistors	TF
	3 bimetallic switches	TH
Temperature detection	1 or 3 x PT100	PT
	1 x KTY84-130	KY
Backstop	Instead of a brake; CW or CCW direction of rotation blocked	RS
Plug connectors	Integrated in terminal box	IS
	Mounted on (types from Harting)	AC.. / AS.. / AM..
Forced cooling fan		V
Canopy		C
Air filter		LF
Fan	Reduction of the noise level	LN
	Metal	AL
	Heavy (additional inertia)	Z
Condensation drain holes		DH
2nd shaft end		2W
MOVIMOT® (DR71 ... 132)		MM with size designation
MOVI-SWITCH® (DR71 ... 100)		MSW

SEW-EURODRIVE is right there for you:

Argentina

Tel. +54 3327 4572-84
Fax +54 3327 4572-21
sewar@sew-eurodrive.com.ar

Australia

Tel. +61 3 9933-1000
Fax +61 3 9933-1003
enquires@sew-eurodrive.com.au

Austria

Tel. +43 1 617 55 00-0
Fax +43 1 617 55 00-30
sew@sew-eurodrive.at

Belarus

Tel. +375 17 298 47 56
Fax +375 17 298 47 54
sales@sew.by

Belgium

Tel. +32 16 386-311
Fax +32 16 386-336
info@sew-eurodrive.be

Brazil

Tel. +55 19 3835-8000
sew@sew.com.br

Canada

Tel. +1 905 791-1553
Fax +1 905 791-2999
marketing@sew-eurodrive.ca

Chile

Tel. +56 2 2757 7000
Fax +56 2 2757 7001
ventas@sew-eurodrive.cl

China

Tel. +86 22 25322612
Fax +86 22 25323273
info@sew-eurodrive.cn

Colombia

Tel. +57 1 54750-50
Fax +57 1 54750-44
sew@sew-eurodrive.com.co

Czech Republic

Tel. +420 255 709 601
Fax +420 235 350 613
sew@sew-eurodrive.cz

Denmark

Tel. +45 43 9585-00
Fax +45 43 9585-09
sew@sew-eurodrive.dk

Finland

Tel. +358 201 589-300
Fax +358 3 7806-211
sew@sew.fi

France

Tel. +33 3 88 73 67 00
Fax +33 3 88 73 66 00
sew@usocome.com

Great Britain

Tel. +44 1924 893-855
Fax +44 1924 893-702
info@sew-eurodrive.co.uk

Hong Kong

Tel. +852 36902200
Fax +852 36902211
contact@sew-eurodrive.hk

Hungary

Tel. +36 1 437 06-58
Fax +36 1 437 06-50
office@sew-eurodrive.hu

India

Tel. +91 265 3045200
Fax +91 265 3045300
marketing@seweurodriveindia.com

Italy

Tel. +39 02 96 9801
Fax +39 02 96 980 999
sewit@sew-eurodrive.it

Ivory Coast

Tel. +225 21 21 81 05
Fax +225 21 25 30 47
info@sew-eurodrive.ci

Japan

Tel. +81 538 373811
Fax +81 538 373814
sewjapan@sew-eurodrive.co.jp

Kazakhstan

Tel. +7 727 238 1404
Fax +7 727 243 2696
sew@sew-eurodrive.kz

Malaysia

Tel. +60 7 3549409
Fax +60 7 3541404
sales@sew-eurodrive.com.my

Mexico

Tel. +52 442 1030-300
Fax +52 442 1030-301
scmexico@seweurodrive.com.mx

Mongolia

Tel. +976 77109997
Fax +976 77109997
sew@sew-eurodrive.mn

Morocco

Tel. +212 523 32 27 80/81
Fax +212 523 32 27 89
sew@sew-eurodrive.ma

Netherlands

Tel. +31 10 4463-700
Fax +31 10 4155-552
info@sew-eurodrive.nl

New Zealand

Tel. +64 9 2745627
Fax +64 9 2740165
sales@sew-eurodrive.co.nz

Norway

Tel. +47 69 241-020
Fax +47 69 241-040
sew@sew-eurodrive.no

Paraguay

Tel. +595 991 519695
Fax +595 21 3285539
sewpy@sew-eurodrive.com.py

Peru

Tel. +51 1 3495280
Fax +51 1 3493002
sewperu@sew-eurodrive.com.pe

Poland

Tel. +48 42 676 53 00
Fax +48 42 676 53 49
sew@sew-eurodrive.pl

Portugal

Tel. +351 231 20 9670
Fax +351 231 20 3685
infosew@sew-eurodrive.pt

Russia

Tel. +7 812 3332522
Fax +7 812 3332523
sew@sew-eurodrive.ru

Singapore

Tel. +65 68621701
Fax +65 68612827
sewsingapore@sew-eurodrive.com

Slovakia

Tel. +421 2 33595 202
Fax +421 2 33595 200
sew@sew-eurodrive.sk

South Africa

Tel. +27 11 248 7000
Fax +27 11 248 7289
info@sew.co.za

South Korea

Tel. +82 31 492-8051
Fax +82 31 492-8056
master.korea@sew-eurodrive.com

Spain

Tel. +34 94 4318470
Fax +34 94 4318471
sew.spain@sew-eurodrive.es

Sweden

Tel. +46 36 3442 00
Fax +46 36 3442 80
info@sew-eurodrive.se

Switzerland

Tel. +41 61 41717-17
Fax +41 61 41717-00
info@imhof-sew.ch

Tanzania

Tel. +255 22 277 5780
Fax +255 22 277 5788
uroos@sew.co.tz

Thailand

Tel. +66 38 454281
Fax +66 38 454288
sewthailand@sew-eurodrive.com

Turkey

Tel. +90 262 999 1000-04
Fax +90 262 999 1009
sew@sew-eurodrive.com.tr

Ukraine

Tel. +380 56 370 3211
Fax +380 56 372 2078
sew@sew-eurodrive.ua

Uruguay

Tel. +598 2 2118189
Fax +598 2 2118190
sewuy@sew-eurodrive.com.uy

USA

Tel. +1 864 439-7537
Fax +1 864 439-7830
cslyman@seweurodrive.com

Venezuela

Tel. +58 241 832-9804
Fax +58 241 838-6275
ventas@sew-eurodrive.com.ve

How we're driving the world



SEW-EURODRIVE
Driving the world

Fast. Up-to-date. Online: www.driveworld.de/en

ClimatePartner
climate neutral
print product

SEW
EURODRIVE

SEW-EURODRIVE GmbH & Co KG
P.O.Box 30 23
76642 Bruchsal/Germany
Tel. +49 7251 75-0
Fax +49 7251 75-1970
sew@sew-eurodrive.com

→ www.sew-eurodrive.com